



# Track-Dumper



snowblade



hydr. front loader



light cargo tray

**RC 550**



# Track-Dumper RC 550

## Technical Data

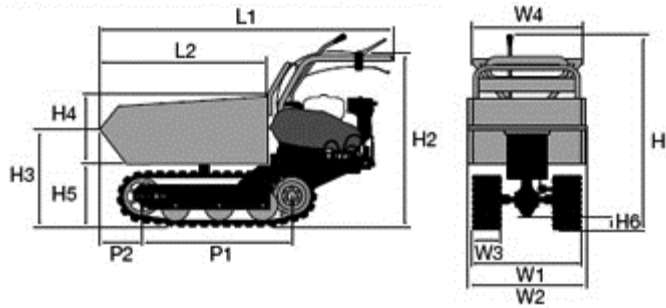

	mm	inches
L1	1575	62.01
L2	915	36.02
H1	1020	40.16
H2	900	35.43
H3	515-725	20.28 - 28.54
H4	405	15.94
H5	320	12.60
H6	70	2.76
W1	622	24.49
W2	622	24.49
W3	-	-
W4	620	24.41
P1	785	30.91
P2	265	10.43

Engine	
Honda	GX 160
Type	1 cyl. / 4-stroke
Displacement	160 cm <sup>3</sup>
Engine output	4.21 kW / 5.5 HP
Revolution speed	3600/rpm
Starter	Reversing Starter
Air filter	Dry Cartridge
Fuel filter	Sieve

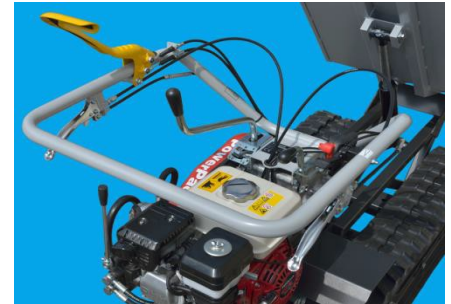

<b>Drive</b>	Toothed gearing, shifting in oil-bath
<b>Brake</b>	Automatic safety brake
<b>Guidance</b>	Steering brake
<b>Characteristic</b>	Hydraulic tipping device



hydraulic tipping

Operational characteristics	
Weight	215 kg / 474 lbs.
Payload max.	550 kg / 1213 lbs.
Tipping device	Hydraulic
Climbing ability	Max. 26° (50%)
Working speed	1.9 km/h / 1.2 mph 1st gear forward 3.2 km/h / 2.0 mph 2nd gear forward 4.1 km/h / 2.5 mph 3rd gear forward 7.0 km/h / 4.3 mph 4th gear forward 1.9 km/h / 1.2mph 1st gear reverse 3.1 km/h / 1.9 mph 2nd gear reverse



orders@gnhardscape.com  
www.greatnorthhardscape.com  
1.800.720.7627